

Three Zone Adjustable Feed Equalizer 48" FS (2)

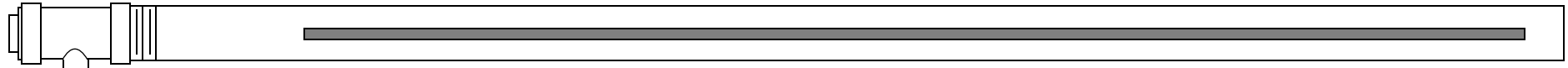

Standard Pipe Burner 72" FS (4)

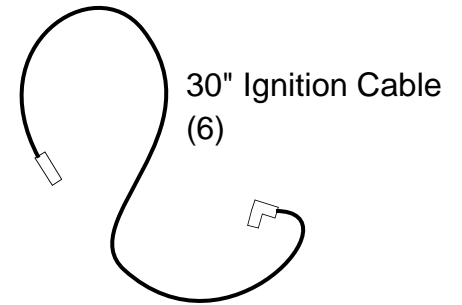
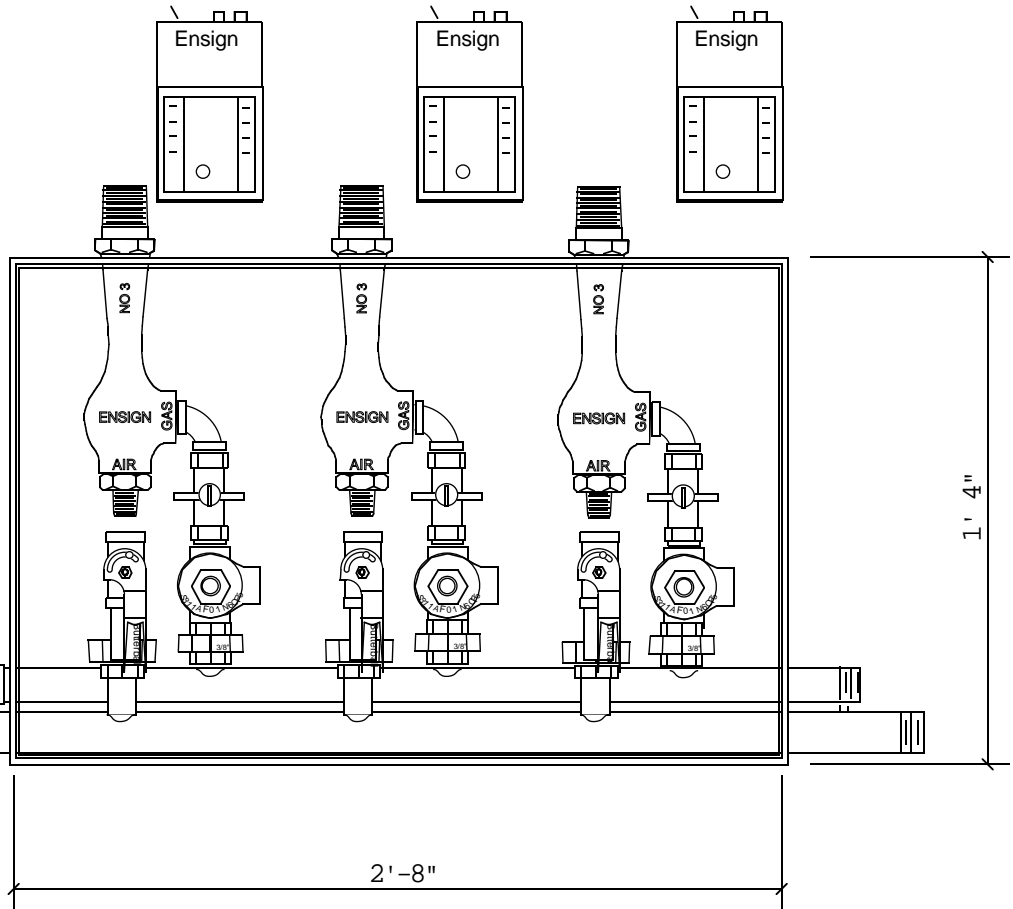

(2) Sets Remote Mixer Panels with Hinged Covers, support chain and keyed latch.

1,050,000 BTU Combustion Supply System
Outputs to (2) 3 Burner remote panels with all
Required Safeties

ENSIGN Ribbon Burners LLC
101 Secor Lane Pelham Manor NY 10803

Remote Mixer System for 3 Burners

ENSIGN Ribbon Burners LLC

101 Secor Lane Pelham Manor NY 10803

Combustion Supply System 1MBTU

10/23/98

RevisionE

Combustion Supply system comes complete with 3 HP Regenerative type combustion air blower, with pressure relief valve, air filter, all piping, Double gas safety valve, flame monitoring and all electrical components. The system is fully prewired. To supply (6) Burners at 175,000 BTU's Each. (2) Hinged cover remote boxes for (3) #3-FJ Fueljectors, valves and solenoids w/ mini manifold. (6) Spark N Sense modules to be supplied for remote mounting. System to be capable of supplying 1,050,000 BTU's Total.

System STCUHE-RW

Electrical Control Panel

13 1/4"

2'-8 1/2"

1'-9"

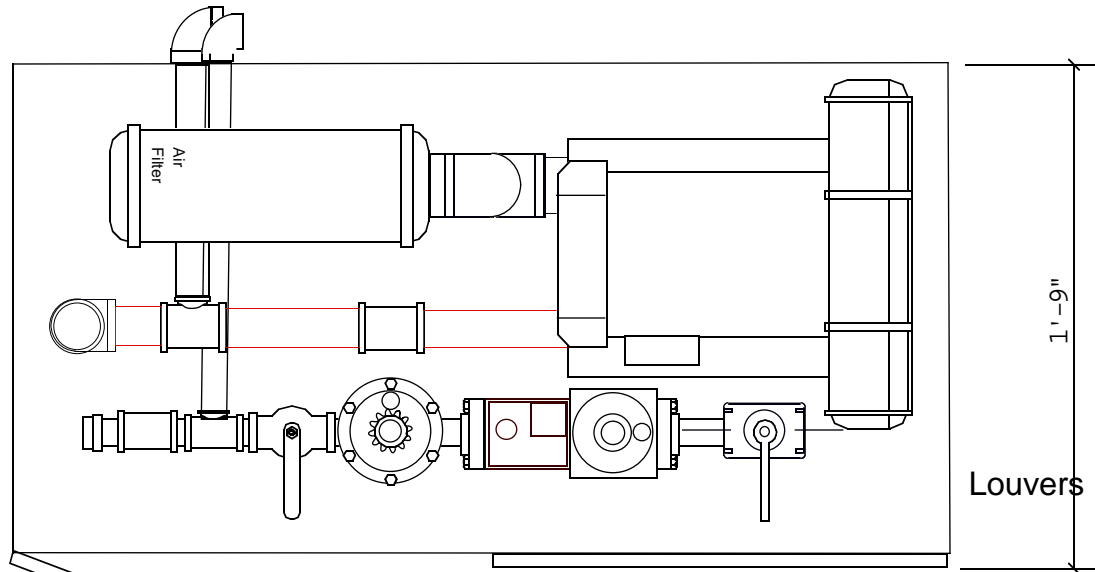
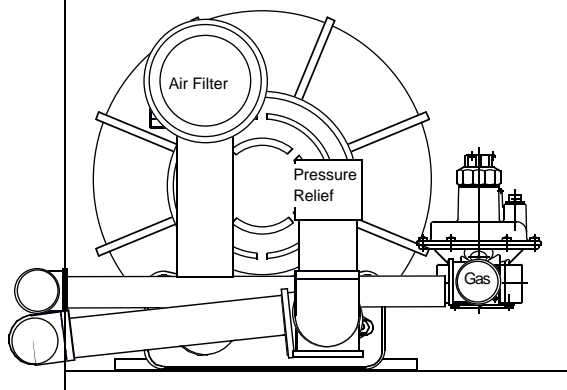

Louvers

Hinged Doors

Enclosure to have back & 2 sides removable, Hinged Doors

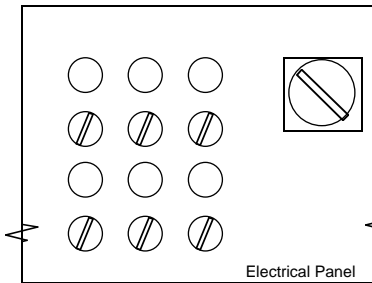

Electrical Panel

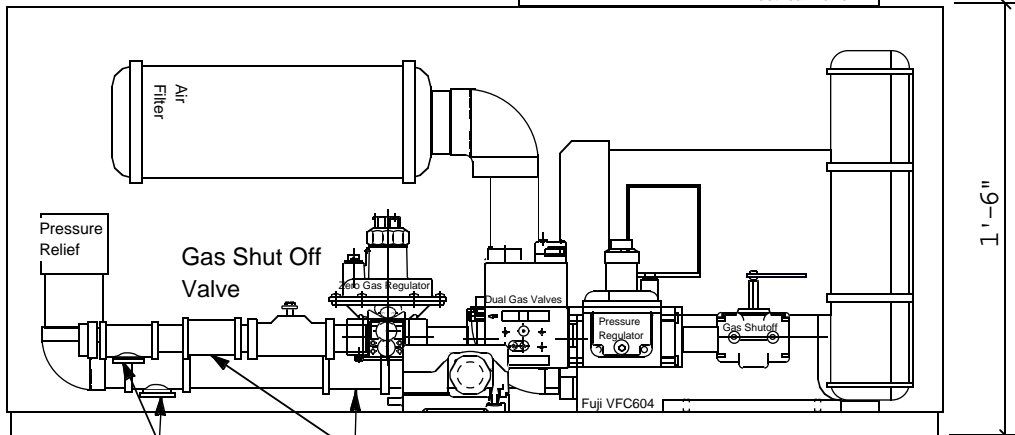

1'-6"

Air & Gas to Panel 1
Air & Gas to Panel 2

3'-3"